

Mold Components

KTM Canada Head Office: 16-342 Bronte St. South, Milton, ON Canada, L9T 5B7
 Phone: (905) 878-3788 Fax: (905) 878-0900 Email: Info@kingstool.com Website: www.kingstool.com

KTM Imperial Screw in Core Pin

Material: O1 RC34-40 (material can be modified)

Catalogue Name	D +0.000" -0.0006"	THREAD	THREAD DEPTH	RECOMMENDED HEX	B MIN HEIGHT
SCPA-	3/16"	#8-32	0.312"	5/32"	1/4"
SCPB-	1/4"	#10-24	0.450"	5/32"	1/4"
SCPC-	1/4"	#10-24	0.450"	3/16"	1/4"
SCPD-	9/32"	#10-24	0.450"	7/32"	1/4"

Standard Delivery: 2-3 Weeks depending on quantity

ORDERING USING 3D CAD DATA SAMPLE

Ordering a Screw in Core Pin with #10-24 Thread with a 5/32 Hex Head made to your 3D Cad file.

Part Name	Your File Name
↓	↓
SCPB	- CORE INSERT CP#1.STP

Material Options:

- O1 RC34-40
- Mold Max XL
- Other

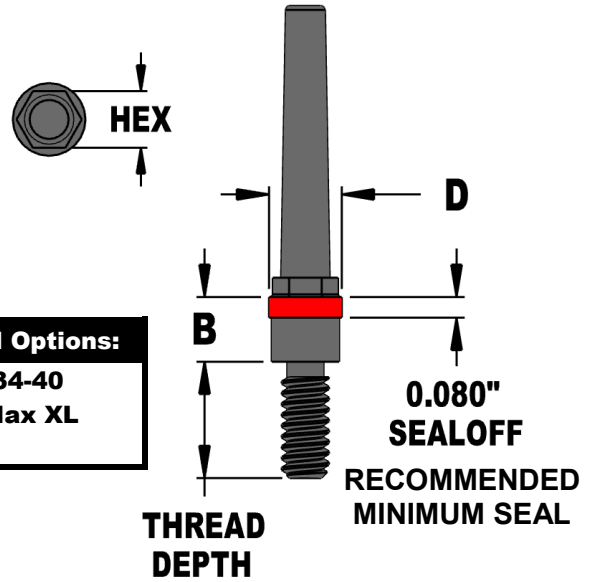

Custom Made to your specifications. Delivered and ready to be installed.

Typical Application for Custom KTM SCREW IN CORE PINS:

- Capturing boss details with KTM SCREW IN CORE PINS saves time and allows for easy replacement of details in potential wearing locations
- Use KTM SCREW IN CORE Pin in place of Core Pins when there are obstruction such as water lines and lifter rods

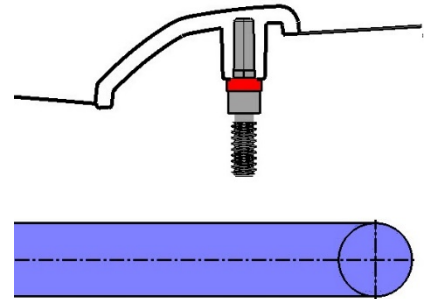

KTM SCREW IN CORE PINS CAN BE CUSTOMIZED TO YOUR SPECIFICATIONS, SEND US YOUR 3D FILES WITH MATERIAL SPECIFICATIONS

Custom Installation tooling can be supplied by KTM. Please Contact KTM for Further