



Mold Components

KTM Canada Head Office: 56 Steeles Ave. UNIT#35 Milton, ON Canada, L9T 4W9
 Phone: (905) 878-3788 Fax: (905) 878-0900 Email: Info@kingstool.com Website: www.kingstool.com

KTM Fix Series Lifter Carriage Assembly

Material: S45C, 4140, Aluminum Bronze

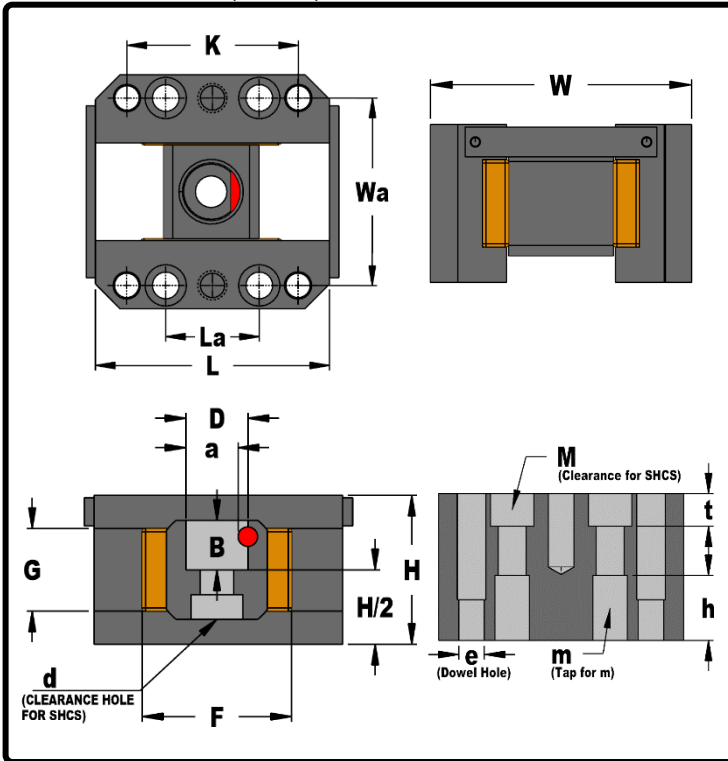

Imperial (Inch)				
Catalogue Name	M	m	e	d
625 KLCA-FX-XXX	1/4 SHCS	5/16-18" NC	1/4"	5/16 SHCS
75 KLCA-FX-XXX	5/16 SHCS	1/2-13" NC	5/16"	3/8 SHCS
100 KLCA-FX-XXX	5/16 SHCS	1/2-13" NC	5/16"	1/2 SHCS
125 KLCA-FX-XXX	5/16 SHCS	1/2-13" NC	5/16"	1/2 SHCS
150 KLCA-FX-XXX	3/8 SHCS	1/2-13" NC	3/8"	5/8 SHCS
75 KLCA-FX-4L-XXX	5/16 SHCS	1/2-13" NC	5/16"	3/8 SHCS
100 KLCA-FX-5L-XXX	5/16 SHCS	1/2-13" NC	5/16"	1/2 SHCS
125 KLCA-FX-6L-XXX	5/16 SHCS	1/2-13" NC	5/16"	1/2 SHCS
150 KLCA-FX-6.75L-XXX	3/8 SHCS	1/2-13" NC	3/8"	5/8 SHCS

Metric (mm)				
Catalogue Name	M	m	e	d
M16 KLCA-FX-XXX	M6 SHCS	M8x1.25	6mm	M8 SHCS
M20 KLCA-FX-XXX	M8 SHCS	M10x1.5	8mm	M10 SHCS
M25 KLCA-FX-XXX	M8 SHCS	M10x1.5	8mm	M12 SHCS
M30 KLCA-FX-XXX	M8 SHCS	M10x1.5	8mm	M12 SHCS
M35 KLCA-FX-XXX	M10 SHCS	M12x1.5	10mm	M12 SHCS
M40 KLCA-FX-XXX	M10 SHCS	M12x1.5	10mm	M16 SHCS

Imperial (Inch)													
Catalogue Name	D	W	Wa	L	La	K	H	h	a	F	G	B	t
625 KLCA-FX-XXX	0.626"	2.52"	1.969"	2.8"	0.98"	1.969"	1.575"	0.6"	0.531"	1.8"	0.95"	0.472"	0.26"
75 KLCA-FX-XXX	0.750"	3.0"	2.400"	3.0"	1.20"	2.200"	1.8"	0.8"	0.630"	1.8"	1.00"	0.598"	0.40"
100 KLCA-FX-XXX	1.000"	3.2"	2.500"	3.4"	1.50"	2.500"	1.8"	0.8"	0.880"	2.0"	1.00"	0.689"	0.40"
125 KLCA-FX-XXX	1.250"	3.5"	2.800"	4.0"	2.00"	3.000"	2.2"	0.9"	1.125"	2.4"	1.20"	0.750"	0.40"
150 KLCA-FX-XXX	1.500"	4.4"	3.600"	5.0"	2.00"	3.400"	2.6"	1.3"	1.350"	3.2"	1.50"	0.902"	0.59"
75 KLCA-FX-4L-XXX	0.750"	3.0"	2.400"	4.0"	2.20"	3.197"	1.8"	0.8"	0.630"	1.8"	1.00"	0.598"	0.40"
100 KLCA-FX-5L-XXX	1.000"	3.2"	2.500"	5.0"	3.10"	4.095"	1.8"	0.8"	0.880"	2.0"	1.00"	0.689"	0.40"
125 KLCA-FX-6L-XXX	1.250"	3.5"	2.800"	6.0"	4.00"	5.001"	2.2"	0.8"	1.125"	2.4"	1.20"	0.750"	0.40"
150 KLCA-FX-6.75L-XXX	1.500"	4.4"	3.600"	6.75"	3.75"	5.150"	2.6"	1.3"	1.350"	3.2"	1.50"	0.902"	0.59"

Metric (mm)													
Catalogue Name	D	W	Wa	L	La	K	H	h	a	F	G	B	t
M16 KLCA-FX-XXX	16mm	64mm	50mm	70mm	25mm	50mm	40mm	20mm	13mm	45mm	24mm	12mm	6.5mm
M20 KLCA-FX-XXX	20mm	76mm	60mm	75mm	30mm	55mm	46mm	25mm	17mm	45mm	24mm	15mm	8.5mm
M25 KLCA-FX-XXX	25mm	81mm	65mm	85mm	40mm	65mm	48mm	25mm	22mm	50mm	26mm	17.5mm	8.5mm
M30 KLCA-FX-XXX	30mm	88mm	72mm	100mm	50mm	80mm	54mm	25mm	27mm	60mm	30mm	19mm	8.5mm
M35 KLCA-FX-XXX	35mm	100mm	80mm	115mm	50mm	85mm	60mm	30mm	31mm	70mm	34mm	20mm	6.5mm
M40 KLCA-FX-XXX	40mm	108mm	88mm	125mm	50mm	85mm	65mm	30mm	36mm	80mm	38mm	21.5mm	7.0mm

For Graphite Impregnated Aluminum Bronze, add G in front of the catalogue name. Example: 75 **G**KLCA-FX-01

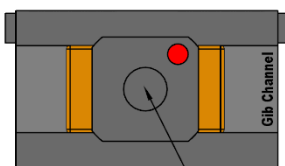

Pivoting point for Acceleration & Deceleration is about center of Gib Channel

Acceleration & Deceleration Order Format	Equivalent
75 KLCA-FX-005	0.5 Degree
75 KLCA-FX-05	5 Degree
75 KLCA-FX-055	5.5 Degree
75 KLCA-FX-10	10 Degree

Contact KTM for angles above 10 Degree

CONTACT KTM TO REQUEST FOR 3D FILES OR FOR CUSTOM LIFTER CARRIAGES