



Mold Components

KTM Canada Head Office: 56 Steeles Ave. UNIT#35 Milton, ON Canada, L9T 4W9
 Phone: (905) 878-3788 Fax: (905) 878-0900 Email: Info@kingstool.com Website: www.kingstool.com

KTM TY Series Lifter Carriage Assembly

Material: S45C, 4140, Aluminum Bronze

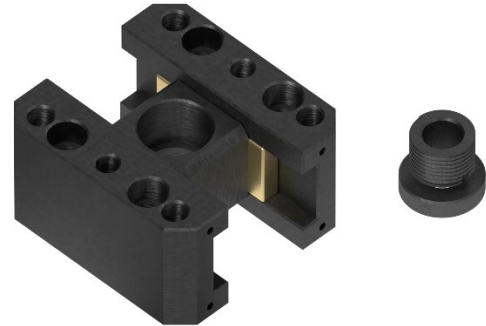
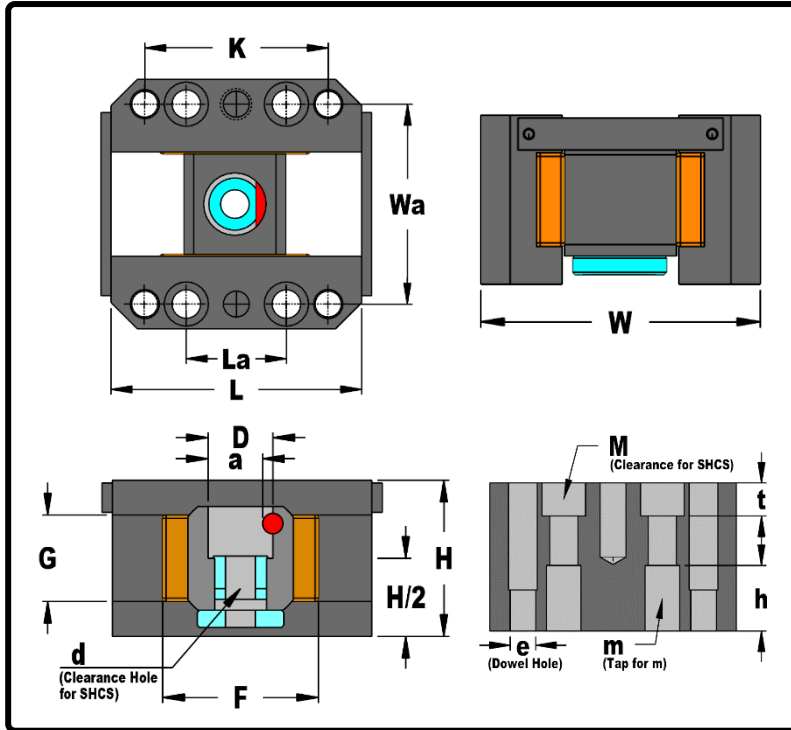

Imperial (Inch)	M	m	e
75 KLCA-TY-XXX	5/16 SHCS	1/2-13" NC	5/16"
75B KLCA-TY-XXX	5/16 SHCS	1/2-13" NC	5/16"
100 KLCA-TY-XXX	5/16 SHCS	1/2-13" NC	5/16"
125 KLCA-TY-XXX	5/16 SHCS	1/2-13" NC	5/16"
150 KLCA-TY-XXX	3/8 SHCS	1/2-13" NC	3/8"
75 KLCA-TY-4L-XXX	5/16 SHCS	1/2-13" NC	5/16"
100 KLCA-TY-5L-XXX	5/16 SHCS	1/2-13" NC	5/16"
125 KLCA-TY-6L-XXX	5/16 SHCS	1/2-13" NC	5/16"
150 KLCA-TY-6.75L-XXX	3/8 SHCS	1/2-13" NC	3/8"

Metric (mm)	M	m	e
M20 KLCA-TY-XXX	M8 SHCS	M10x1.5	8mm
M25 KLCA-TY-XXX	M8 SHCS	M10x1.5	8mm
M30 KLCA-TY-XXX	M8 SHCS	M10x1.5	8mm
M35 KLCA-TY-XXX	M10 SHCS	M12x1.5	10mm
M40 KLCA-TY-XXX	M10 SHCS	M12x1.5	10mm

Imperial (Inch)	D	W	Wa	L	La	K	H	h	a	F	G	d	t
75 KLCA-TY-XXX	0.750"	3.0"	2.400"	3.0"	1.20"	2.200"	1.8"	0.8"	0.630"	1.8"	1.00"	5/16 SHCS	0.40"
75B KLCA-TY-XXX	0.750"	3.0"	2.400"	3.0"	1.20"	2.200"	1.8"	0.8"	0.630"	1.8"	1.00"	3/8 SHCS	0.40"
100 KLCA-TY-XXX	1.000"	3.2"	2.500"	3.4"	1.50"	2.500"	1.8"	0.8"	0.880"	2.0"	1.00"	1/2 SHCS	0.40"
125 KLCA-TY-XXX	1.250"	3.5"	2.800"	4.0"	2.00"	3.000"	2.2"	0.9"	1.125"	2.4"	1.20"	1/2 SHCS	0.40"
150 KLCA-TY-XXX	1.500"	4.4"	3.600"	5.0"	2.00"	3.400"	2.6"	1.3"	1.350"	3.2"	1.50"	5/8 SHCS	0.59"
75 KLCA-TY-4L-XXX	0.750"	3.0"	2.400"	4.0"	2.20"	3.197"	1.8"	0.8"	0.630"	1.8"	1.00"	5/16 SHCS	0.40"
75B KLCA-TY-4L-XXX	0.750"	3.0"	2.400"	4.0"	2.20"	3.197"	1.8"	0.8"	0.630"	1.8"	1.00"	3/8 SHCS	0.40"
100 KLCA-TY-5L-XXX	1.000"	3.2"	2.500"	5.0"	3.10"	4.095"	1.8"	0.8"	0.880"	2.0"	1.00"	1/2 SHCS	0.40"
125 KLCA-TY-6L-XXX	1.250"	3.5"	2.800"	6.0"	4.00"	5.001"	2.2"	0.8"	1.125"	2.4"	1.20"	1/2 SHCS	0.40"
150 KLCA-TY-6.75L-XXX	1.500"	4.4"	3.600"	6.75"	3.75"	5.150"	2.6"	1.3"	1.350"	3.2"	1.50"	5/8 SHCS	0.59"

Metric (mm)	D	W	Wa	L	La	K	H	h	a	F	G	d	t
M20 KLCA-TY-XXX	20mm	76mm	60mm	75mm	30mm	55mm	46mm	25mm	17mm	45mm	24mm	M10 SHCS	8.5mm
M25 KLCA-TY-XXX	25mm	81mm	65mm	85mm	40mm	65mm	48mm	25mm	22mm	50mm	26mm	M12 SHCS	8.5mm
M30 KLCA-TY-XXX	30mm	88mm	72mm	100mm	50mm	80mm	54mm	25mm	27mm	60mm	30mm	M12 SHCS	8.5mm
M35 KLCA-TY-XXX	35mm	100mm	80mm	115mm	50mm	85mm	60mm	30mm	31mm	70mm	34mm	M12 SHCS	6.5mm
M40 KLCA-TY-XXX	40mm	108mm	88mm	125mm	50mm	85mm	65mm	30mm	36mm	80mm	38mm	M16 SHCS	7.0mm

For Graphite Impregnated Aluminum Bronze, add G in front of the catalogue name. Example: 75 **G**KLCA-TY-01

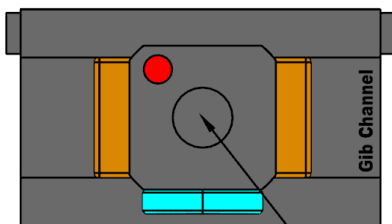

Pivoting point for Acceleration & Deceleration is about center of Gib Channel

Acceleration & Deceleration Order Format	Equivalent
75 KLCA-TY-005	0.5 Degree
75 KLCA-TY-05	5 Degree
75 KLCA-TY-055	5.5 Degree
75 KLCA-TY-10	10 Degree

Contact KTM for angles above 10 Degree

CONTACT KTM TO REQUEST FOR 3D FILES OR FOR CUSTOM LIFTER CARRIAGE ANGLES