

## KTM Lift Puck (Imperial Series)

### Extend thread engagement by welding KTM Lift Puck to plates

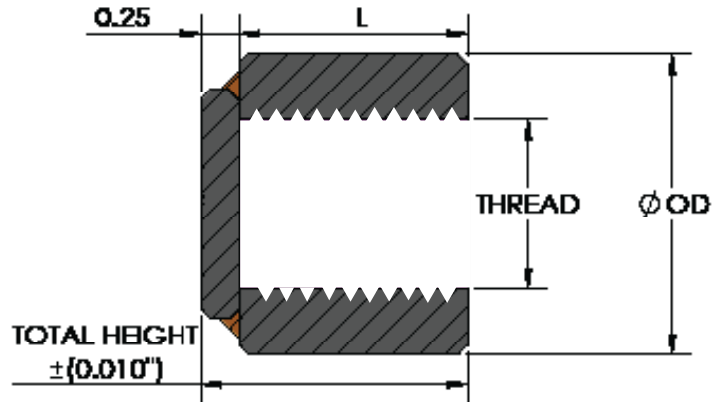

Catalogue Name	(ØOD) Puck Diameter	(THREAD) Thread Size	(L) [Inch] Length	Total Height [Inch]
KTM-LiftPuck-100L1.375	38mm (1.497")	1-8 NC	1.375	1.625
KTM-LiftPuck-125L1.5	50mm (1.968")	1.25-7 NC	1.500	1.750
KTM-LiftPuck-150L1.5	65mm (2.559")	1.50-6 NC	1.500	1.750
KTM-LiftPuck-175L2	75mm (2.953")	1.75-5 NC	2.000	2.250
KTM-LiftPuck-200L2	75mm (2.953)	2-4.5 NC	2.000	2.250

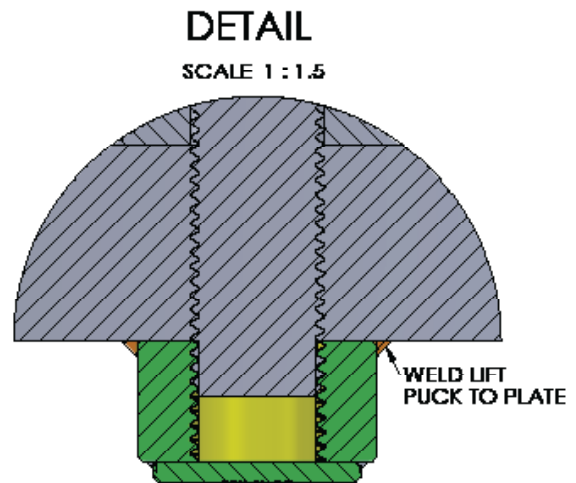
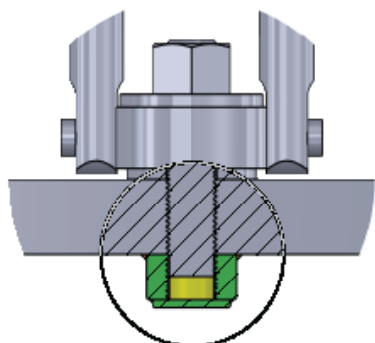
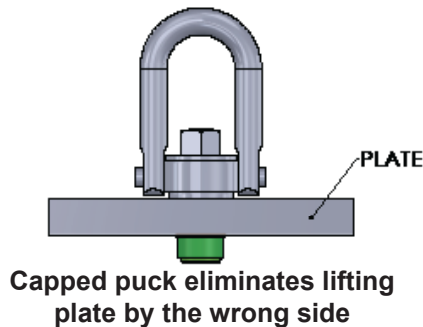

**Welding: Locate/Tighten puck to bolt before welding to match the threads of the tapped hole and puck.**

**Contact KTM For Non-Threaded Lift Pucks or Custom Sizes**