



Mold Components

KTM Canada Head Office: 56 Steeles Ave. UNIT#35 Milton, ON Canada, L9T 4W9
 Phone: (905) 878-3788 Fax: (905) 878-0900 Email: Info@kingstool.com Website: www.kingstool.com

KTM Top Interlocks

Material: (Male O1 58-62 RC Black Oxide), (Female H13 40-44 RC TiN Treated)

Catalogue Name	W +0.000 -0.0004	A +0.000 -0.002	B +0.000 -0.002	C +0.01 -0.01	F 0.0002 Clearance per side	T +0.000 -0.002	R Pocket Radius	S1 +0.01 -0.01	S2 +0.01 -0.01	SHCS Male & Female
KTPINTL1250	1.250"	0.625"	0.500"	0.410"	0.438"	0.625"	0.255"	0.312"	0.875"	#6-32
KTPINTL1500	1.500"	0.875"	0.750"	0.530"	0.500"	0.875"	0.255"	0.437"	1.000"	#8-32
KTPINTL2000	2.000"	1.125"	0.750"	0.660"	0.750"	1.000"	0.380"	0.500"	1.375"	#10-32
KTPINTL3000	3.000"	1.500"	0.750"	0.780"	1.125"	1.125"	0.505"	0.562"	2.250"	1/4-20
KTPINTL3000S	3.000"	1.250"	0.875"	0.750"	1.125"	1.750"	0.505"	0.875"	2.250"	5/16-18
KTPINTL3500	3.500"	1.750"	0.750"	1.000"	1.500"	2.000"	0.505"	1.000"	2.500"	3/8-16

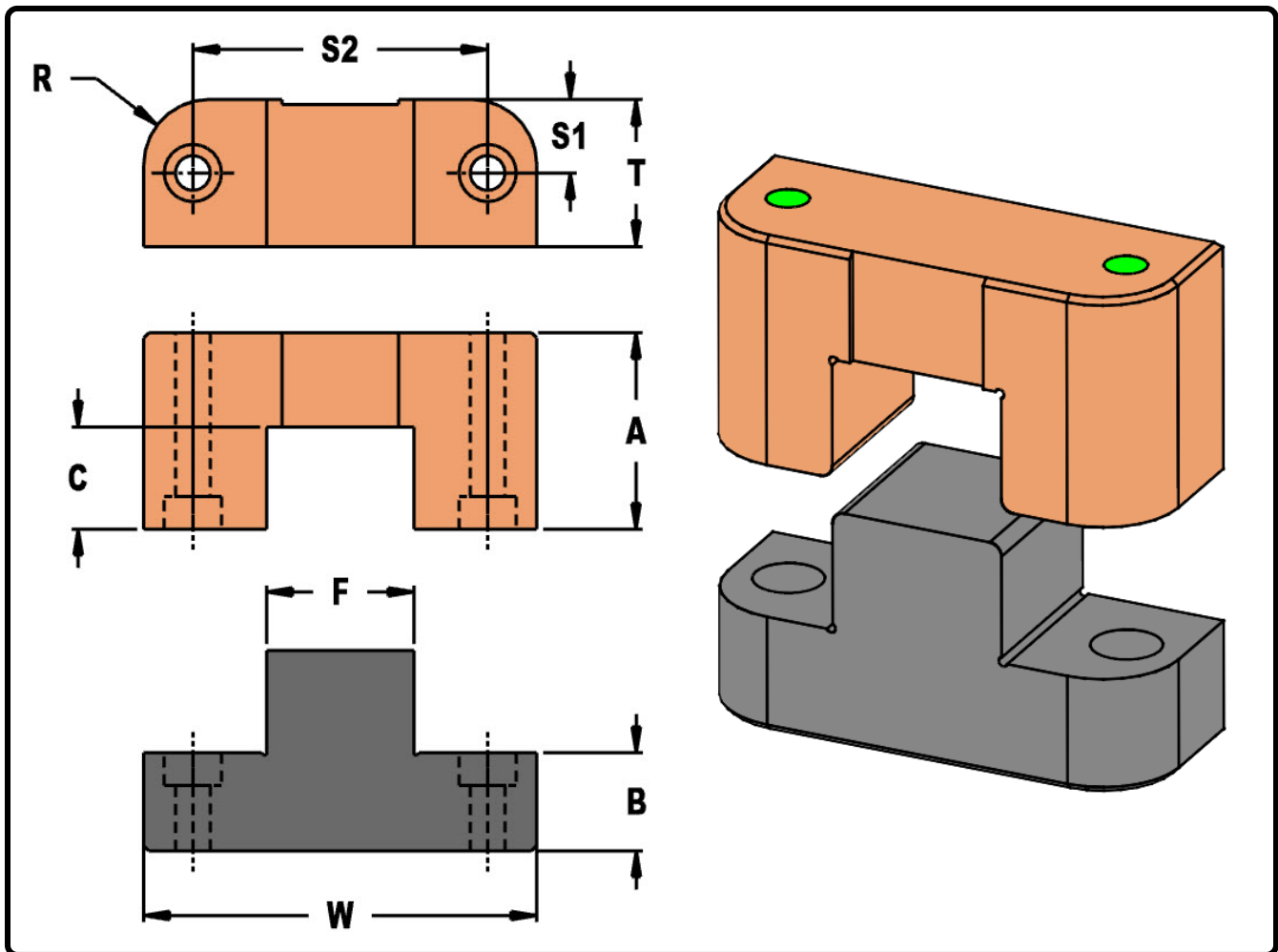

CONTACT KTM TO REQUEST 3D FILES