



# Mold Components

KTM Canada Head Office: 56 Steeles Ave. UNIT#35 Milton, ON Canada, L9T 4W9  
 Phone: (905) 878-3788 Fax: (905) 878-0900 Email: Info@kingstool.com Website: www.kingstool.com

## KTM Pressure Pad L Series

**Material: O1 Harden RC 50-55**

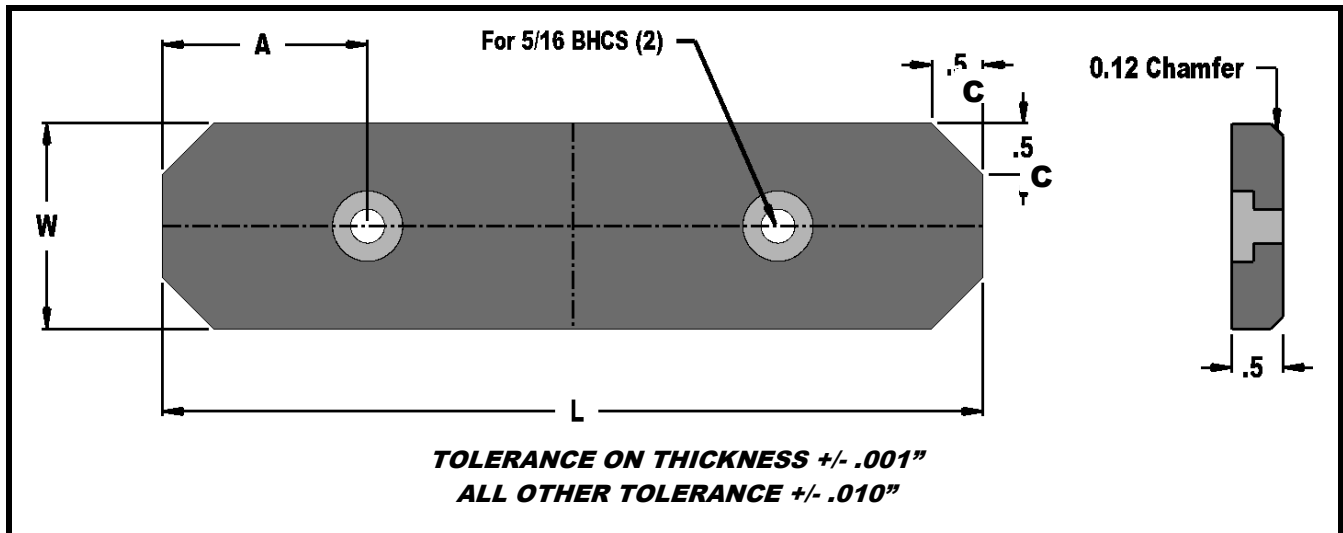

Catalogue Name	W (+/- 0.010")	L (+/- 0.010")	A	C
KTM-PPL-1x3	1	3	0.500	.3
KTM-PPL-1x4		4	1.000	
KTM-PPL-2x2	2	2	0.500	.5
KTM-PPL-2x4		4	1.000	
KTM-PPL-2x6		6	1.500	
KTM-PPL-2x8		8	2.000	
KTM-PPL-2x10		10	2.000	
KTM-PPL-3x2	3	2	0.500	.5
KTM-PPL-3x4		4	1.000	
KTM-PPL-3x6		6	1.500	
KTM-PPL-3x8		8	2.000	
KTM-PPL-3x10		10	2.000	

Use KTM L Series Shims to adjust KTM L Pressure Pad series height.

See Page 53

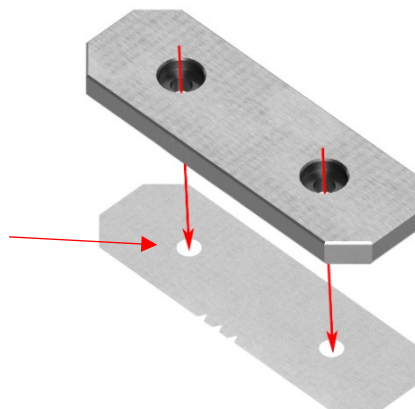

**Contact KTM to request for 3D files**  
**Custom Pressure Pads Available; Tailor Made to Your Specification.**  
**Call for More Information**