



Mold Components

KTM Canada Head Office: 56 Steeles Ave. UNIT#35 Milton, ON Canada, L9T 4W9
 Phone: (905) 878-3788 Fax: (905) 878-0900 Email: Info@kingstool.com Website: www.kingstool.com

KTM Metric Screw In Core Pin

Material: O1 RC34-40 (material can be modified)

Catalogue Name	D +0.00mm -0.015mm	THREAD	THREAD DEPTH	RECOMMENDED HEX	B MIN HEIGHT
SCPM4-	5mm	M4x0.7	8mm	4mm	6.35mm
SCPM5-	6.35mm	M5x0.8	11.43mm	4.5mm	6.35mm
SCPM5A-	7mm	M5x0.8	11.43mm	5mm	6.35mm
SCPM6-	8mm	M6x1.0	11.43mm	5mm	6.35mm

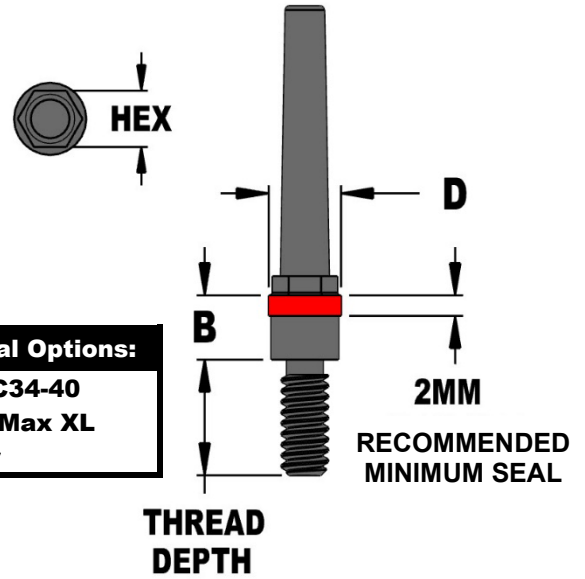

Standard Delivery: 2-3 Weeks depending on quantity

ORDERING USING 3D CAD DATA SAMPLE

Ordering a Screw in Core Pin with M5x0.8 Thread with a 4.5mm Hex Head made to your 3D Cad file.

<p>Catalogue Name</p> <p style="text-align: center;">↓</p> <div style="border: 1px solid red; padding: 2px; text-align: center; width: 80px; margin: auto;">SCPM5</div>	<p>Your File Name</p> <p style="text-align: center;">↓</p> <div style="border: 1px solid red; padding: 2px; text-align: center; width: 200px; margin: auto;">CORE INSERT CP#1.STP</div>
---------------------------------------------------------------------------------------------------------------------------------------------------------------------------------------	-------------------------------------------------------------------------------------------------------------------------------------------------------------------------------------------------------

- Material Options:**

 - O1 RC34-40
 - Mold Max XL
 - Other

Custom Made to your specifications. Delivered and ready to be installed.

Typical Application for Custom KTM SCREW IN CORE PINS:

- Capturing boss details with KTM SCREW IN CORE PINS saves time and allows for easy replacement of details in potential wearing locations
- Use KTM SCREW IN CORE Pin in place of Core Pins when there are obstruction such as water lines and lifter rods

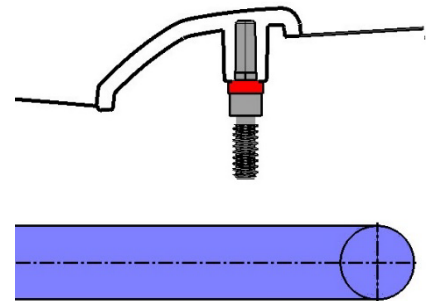

KTM SCREW IN CORE PINS CAN BE CUSTOMIZED TO YOUR SPECIFICATIONS, SEND US YOUR 3D FILES WITH MATERIAL SPECIFICATIONS

Custom Installation tooling can be supplied by KTM. Please Contact KTM for Further Details