

KTM Corner Pin Pads

Material: O1 Harden RC50-55

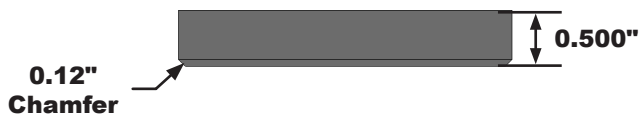
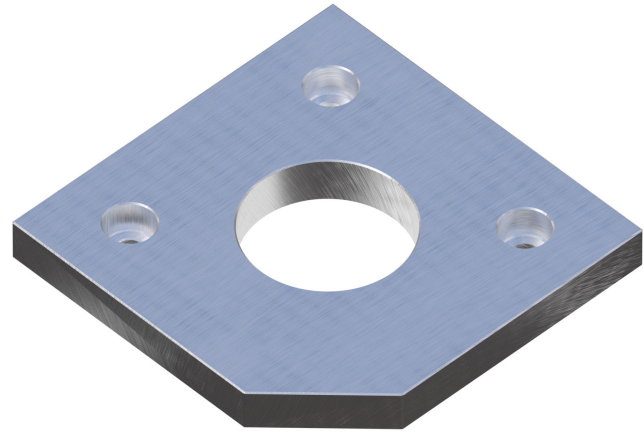
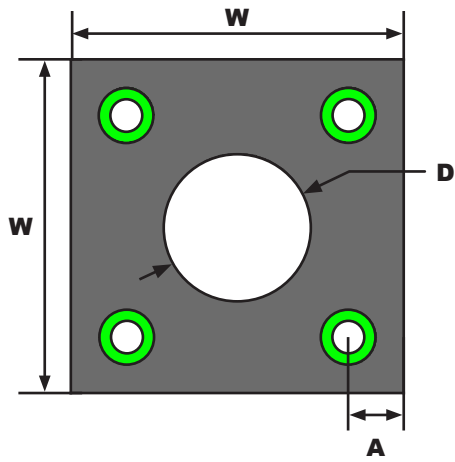

Tolerance: Thickness +/- 0.001", All other: +/- 0.010"

Catalog Name	W	D	A	Mounting Screw	C'Bore Depth
KTM-CPP-3x3-100	3.00"	1.06"	0.50"	1/4" (M6) SHCS	5/16"
KTM-CPP-3x3-125	3.00"	1.31"	0.50"	1/4" (M6) SHCS	5/16"
KTM-CPP-4x4-150	4.00"	1.64"	0.75"	1/4" (M6) SHCS	5/16"
KTM-CPP-4x4-200	4.00"	2.06"	0.75"	1/4" (M6) SHCS	5/16"
KTM-CPP-5x5-250	5.00"	2.56"	0.75"	1/4" (M6) SHCS	5/16"
KTM-CPP-6x6-300	6.00"	3.06"	0.75"	1/4" (M6) SHCS	5/16"

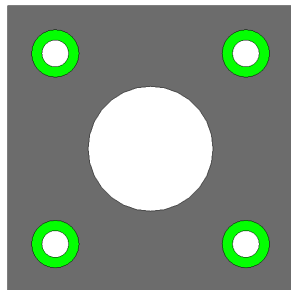

Standard

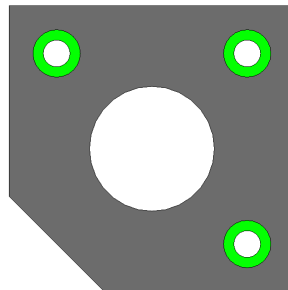

Work Face (WF)

To request the work face version, add WF at the end of the catalog name.

Example: KTM-CPP-3x3-100-WF

Contact KTM to request for 3D files
Custom Corner Pin Pad; Tailor Made to Your Specification.
Call for More Information